

KEY RESIN COMPANY

STANDARD FLOORING DESIGN DETAILS GUIDE

VAPOR BARRIER FOR SLAB ON GRADE	KEY-DTL-1
CONTRACTION/CONTROL JOINT DETAILS	KEY-DTL-2
EXPANSION/ISOLATION JOINT DETAIL	KEY-DTL-3
CONSTRUCTION/COLD JOINT	KEY-DTL-4
BURIED CONTROL JOINT	KEY-DTL-5
EPOXY TERRAZZO TO CARPET TERMINATION	KEY-DTL-6
EPOXY FLOORING KEY-IN TERMINATION	KEY-DTL-7
EPOXY TERRAZZO OVER CONCRETE	KEY-DTL-8
FLANGED DRAIN DETAIL	KEY-DTL-9
TRENCH DETAIL	KEY-DTL-10
COVE DETAIL #1	KEY-DTL-11
COVE DETAIL #2	KEY-DTL-12

Click above to link directly to the design detail of your choice.



4050 Clough Woods Drive
 Batavia, Ohio 45103
 888-943-4532
www.keyresin.com

DATE:	01/04/10	DETAIL: TABLE OF CONTENTS
FILE #:	KEY RESIN FLOORING DETAIL DWGS	

NOTE:
DO NOT PLACE 2" OF SAND
OVER VAPOR BARRIER
REFERENCE ACI-302.IR-04

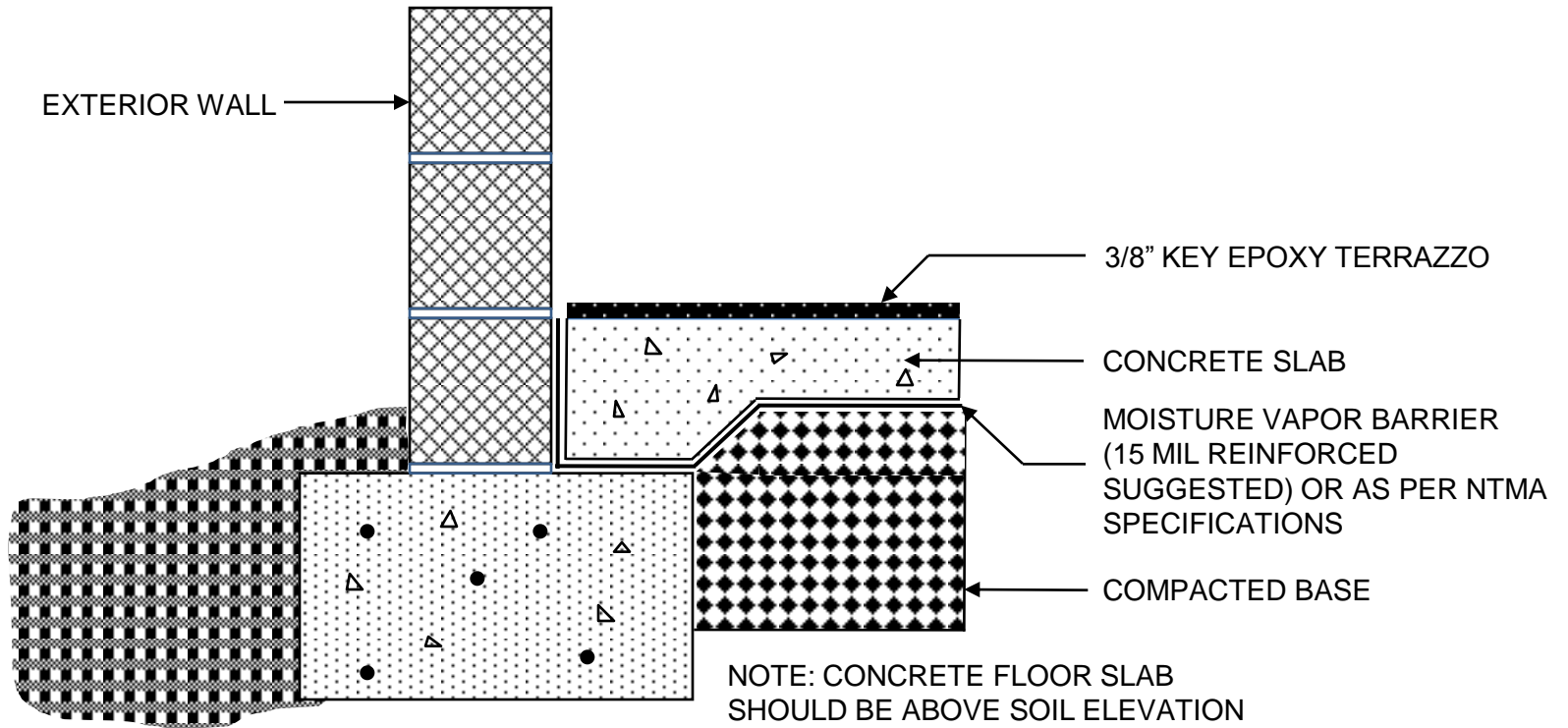

4050 Clough Woods Drive
Batavia, Ohio 45103
888-943-4532
www.keyresin.com

NOT TO
SCALE
DATE:
2/24/08

DETAIL: **VAPOR BARRIER FOR SLAB ON GRADE**
FILE #: **KEY-DTL-1**

CONTRACTION/ CONTROL JOINT

PREFERRED ALTERNATE

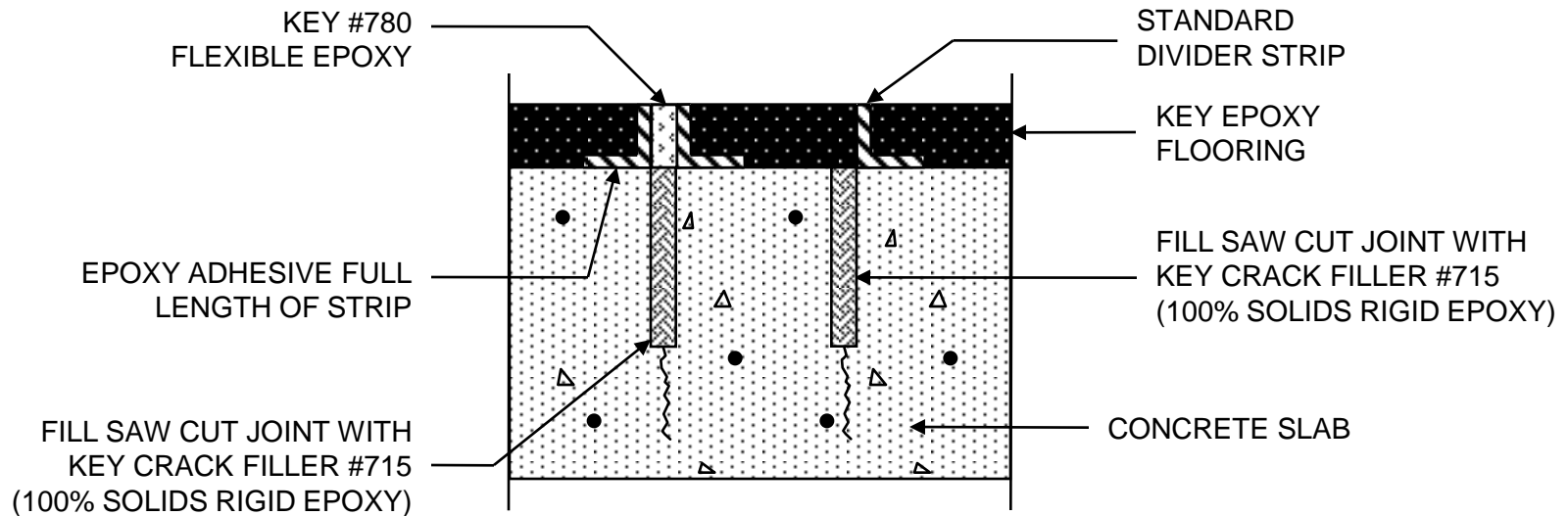

NOTE 1: THIS DETAIL MUST BE USED FOR RADIANT HEATED FLOORS.

OPTION: FOR "ART WORK AREAS," SEE BURIED CONTRACTION JOINT DETAIL. REFER TO DETAIL # KEY-DTL-4



4050 Clough Woods Drive
Batavia, Ohio 45103
888-943-4532
www.keyresin.com

NOT TO
SCALE

DATE:
10/28/09

DETAIL:
JOINT DETAILS

FILE #:
KEY-DTL-2

EXPANSION / ISOLATION JOINT

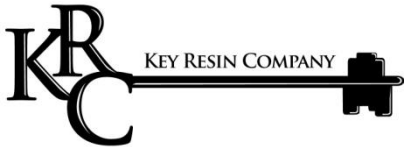
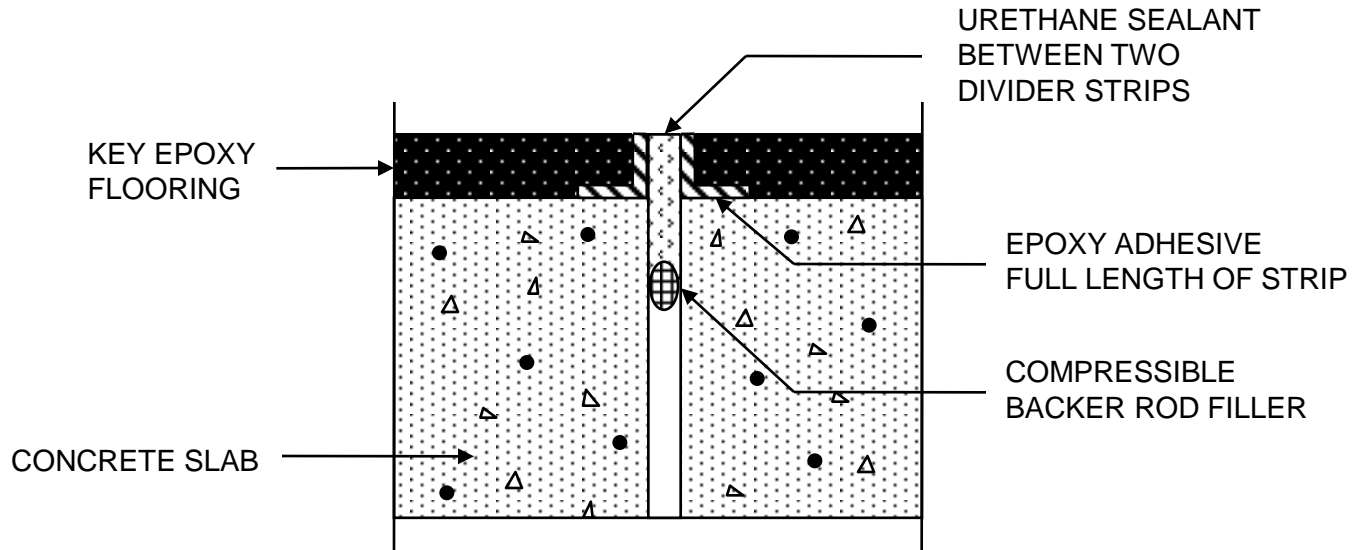

4050 Clough Woods Drive
Batavia, Ohio 45103
888-943-4532
www.keyresin.com

NOT TO
SCALE

DATE:
01/04/10

DETAIL:
JOINT DETAILS

FILE #:
KEY-DTL-3

CONSTRUCTION / COLD JOINT (Next Day Pour Where Joint Has Eased Shoulders or Has Opened)

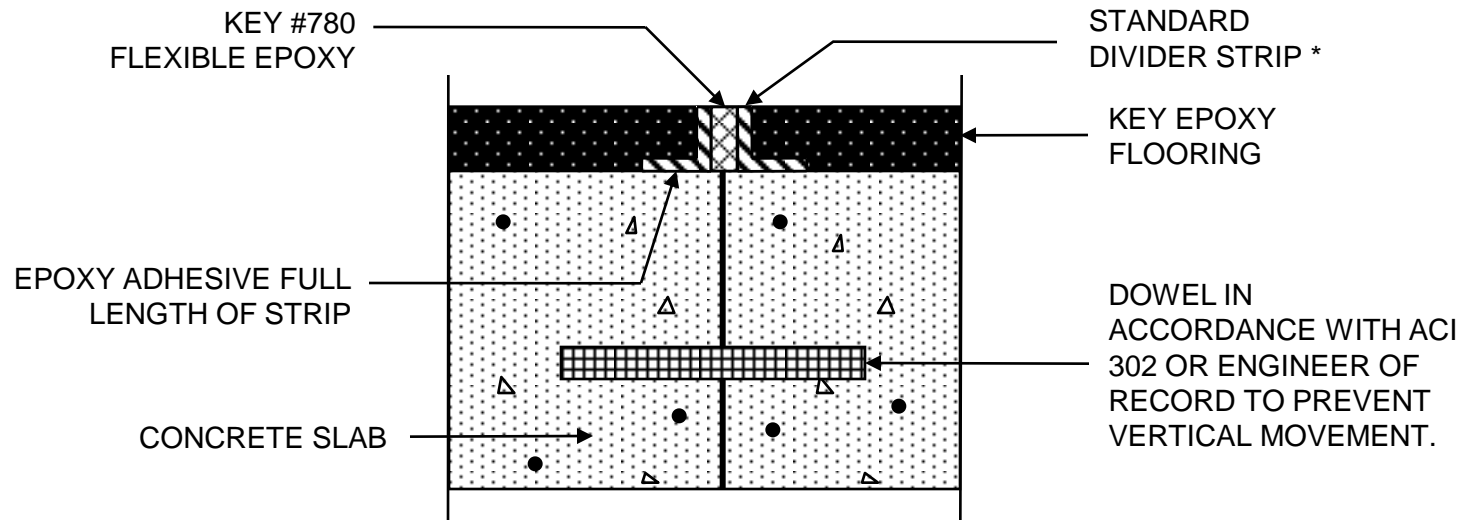

* IF CONSTRUCTION/COLD JOINT HAS NOT OPENED, STRIPS MAY BE SET BACK TO BACK



4050 Clough Woods Drive
Batavia, Ohio 45103
888-943-4532
www.keyresin.com

NOT TO
SCALE

DATE:
01/04/10

DETAIL:
JOINT DETAILS

FILE #:
KEY-DTL-4

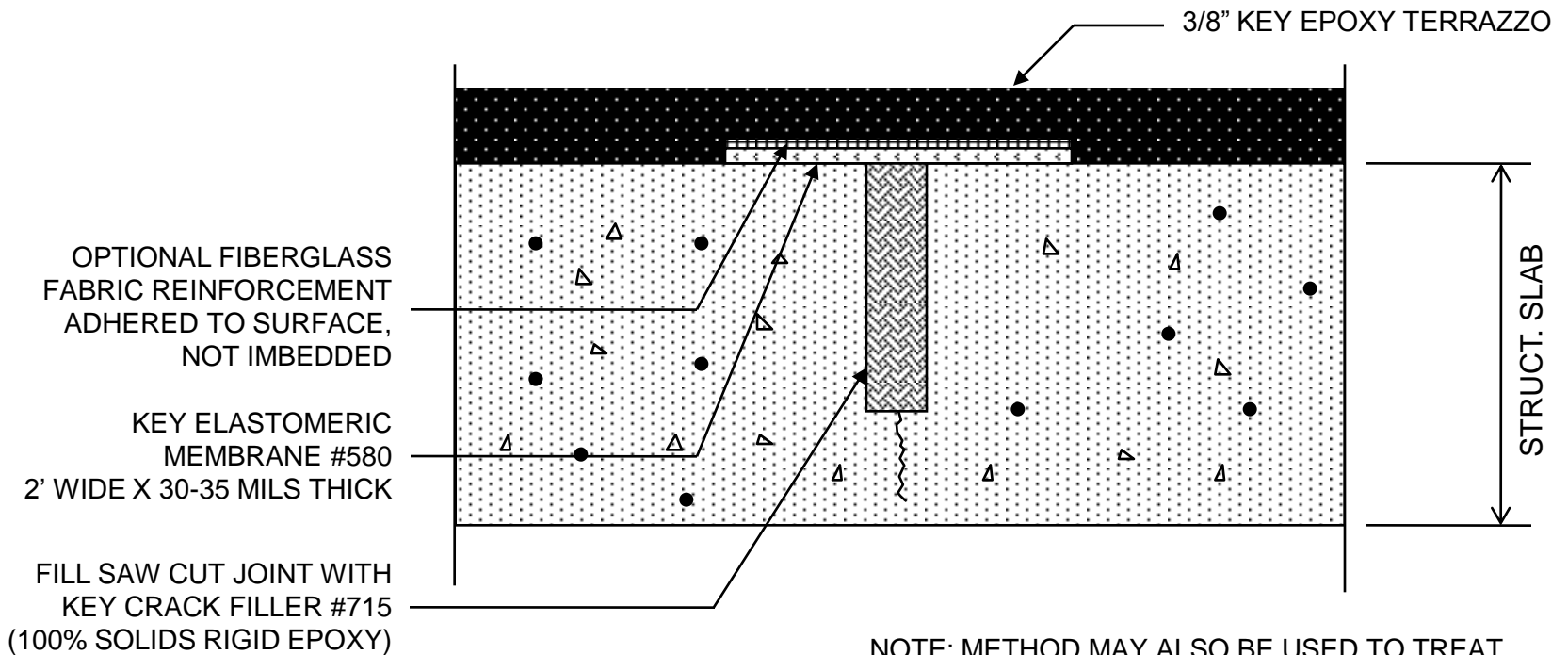

NOTE: METHOD MAY ALSO BE USED TO TREAT CRACKS LARGER THAN HAIRLINE

TREATMENT OF CRACKS IS IN ANTICIPATION OF HORIZONTAL MOVEMENT.



4050 Clough Woods Drive
 Batavia, Ohio 45103
 888-943-4532
www.keyresin.com

NOT TO SCALE
 DATE: 10/28/09

DETAIL: **BURIED CONTROL JOINT**
 FILE #: **KEY-DTL-5**

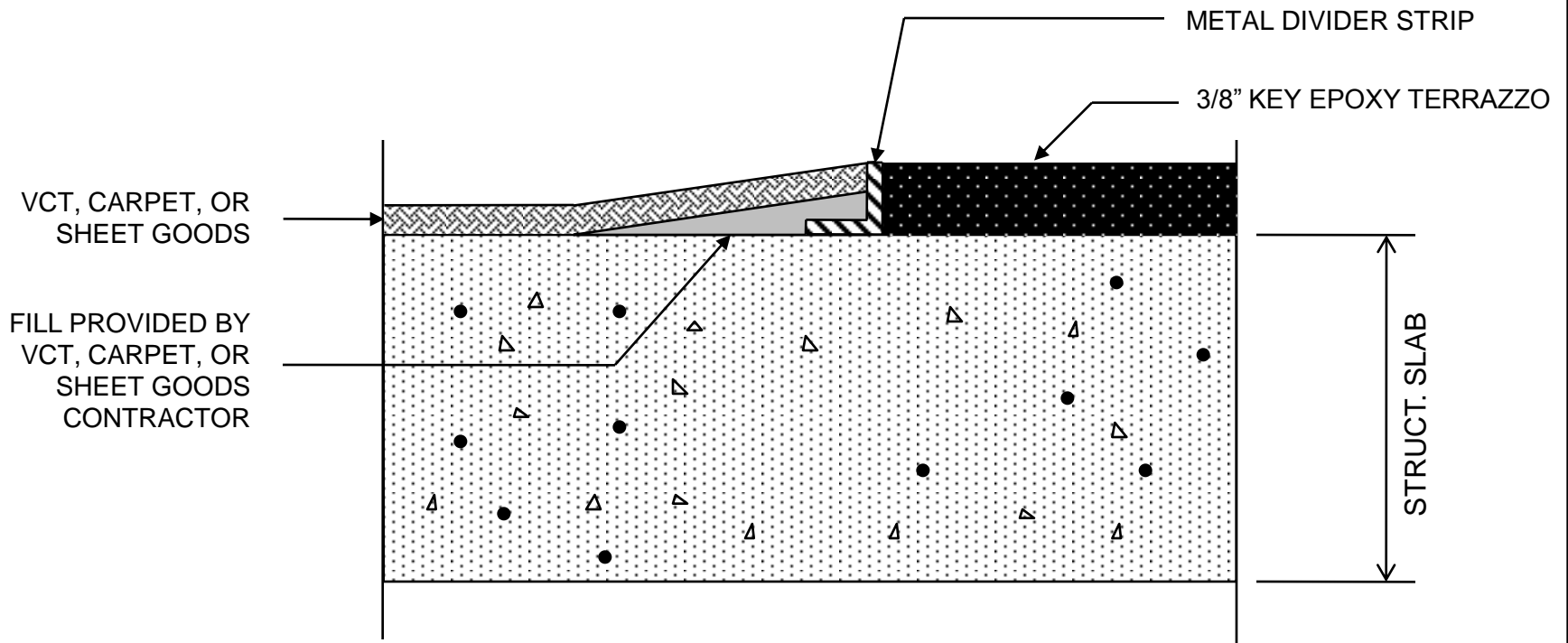

NOTE: EPOXY TERRAZZO TO BE POURED FIRST.
OTHER TRADES TO FINISH AT PROPER ELEVATION



4050 Clough Woods Drive
Batavia, Ohio 45103
888-943-4532
www.keyresin.com

NOT TO
SCALE

DATE:
2/24/08

DETAIL: **EPOXY TERRAZZO CARPET
TERMINATION**

FILE #:
KEY-DTL-6

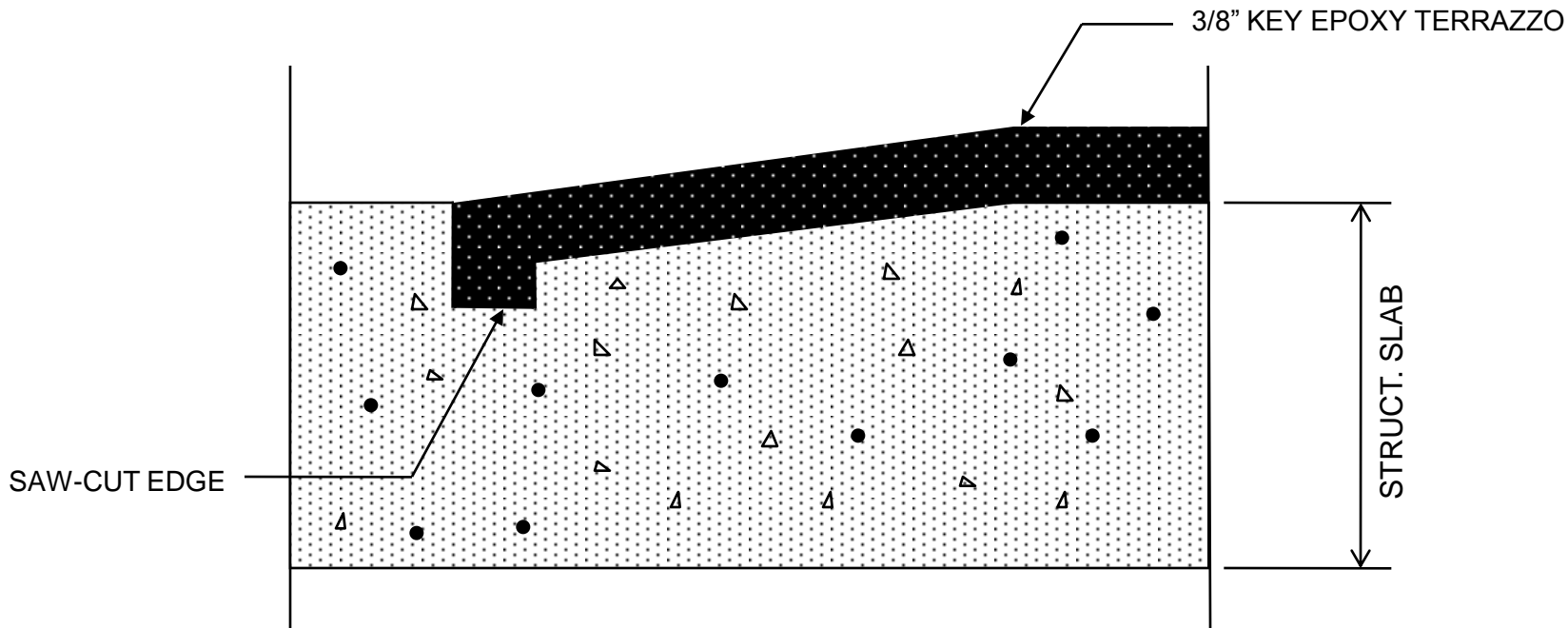

4050 Clough Woods Drive
 Batavia, Ohio 45103
 888-943-4532
www.keyresin.com

NOT TO
 SCALE

DATE:
 2/24/08

DETAIL: **EPOXY FLOORING KEY-IN TERMINATION**

FILE #: **KEY-DTL-7**

KEY RESIN EPOXY TERRAZZO SYSTEM

KEY RESIN #580 FLEXIBLE EPOXY
CRACK ISOLATION MEMBRANE (AS NEEDED)

KEY RESIN #502 PRIMER OR
#635 MOISTURE VAPOR TREATMENT

CONCRETE SUBSTRATE

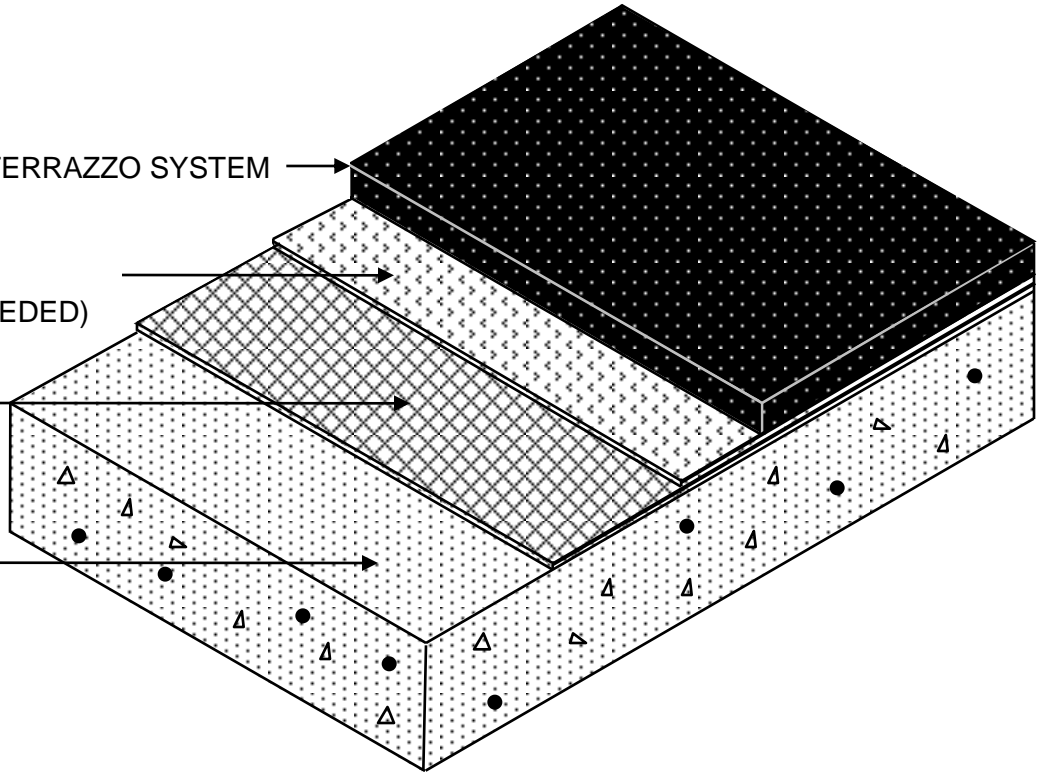

4050 Clough Woods Drive
Batavia, Ohio 45103
888-943-4532
www.keyresin.com

NOT TO
SCALE

DATE:
2/24/08

DETAIL: EPOXY TERRAZZO OVER CONCRETE

FILE #: KEY-DTL-8

DRAIN 1/8" MIN. BELOW TOP OF TOPPING

SLOPE TO DRAIN

WEEP HOLES

KEY RESIN EPOXY
TERRAZZO SYSTEM

CONCRETE SLAB

CHEMICAL RESISTANT
FLANGED DRAIN

NOTE: BE SURE WEEP HOLES ARE NOT
PLUGGED BY MORTAR OR MEMBRANE



4050 Clough Woods Drive
Batavia, Ohio 45103
888-943-4532
www.keyresin.com

NOT TO
SCALE

DATE:
2/24/08

DETAIL:
FLANGED DRAIN DETAIL

FILE #:
KEY-DTL-9

CHEMICAL RESISTANT ANGLE TO HOLD TRENCH GRADING

- STAINLESS STEEL
- PROTRUDED VINYL ESTER OR POLYESTER
- PVC

CHEMICAL RESISTANT MONOLITHIC RESIN FLOORING

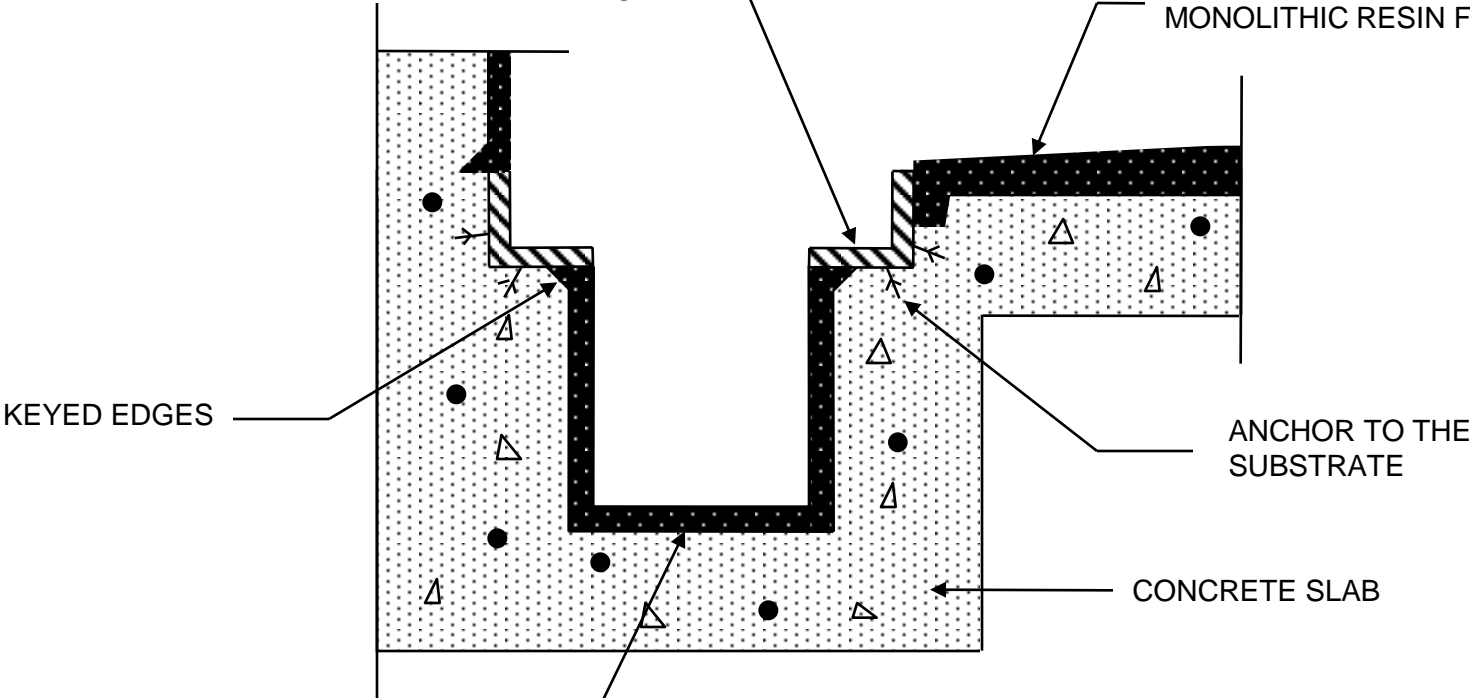

KEYED EDGES

ANCHOR TO THE SUBSTRATE

CONCRETE SLAB

CHEMICAL RESISTANT MONOLITHIC RESIN TRENCH LINING SYSTEM

NOTE: TRENCH LINING AND FLOORING SYSTEM MUST "KEY" INTO THE TRENCH GRADING



4050 Clough Woods Drive
Batavia, Ohio 45103
888-943-4532
www.keyresin.com

NOT TO SCALE
DATE: 2/24/08

DETAIL: TRENCH DETAIL
FILE #: KEY-DTL-10

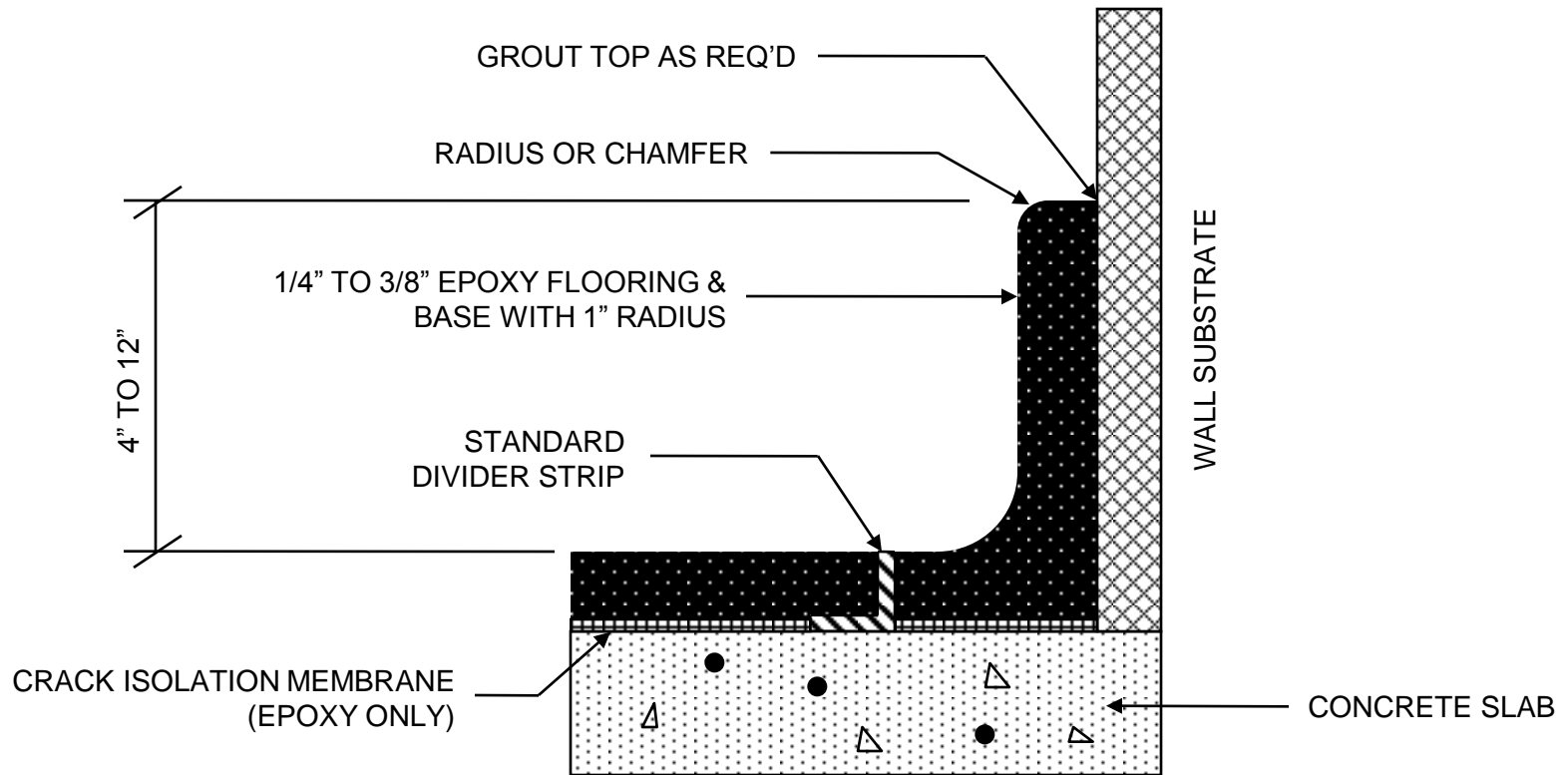

4050 Clough Woods Drive
 Batavia, Ohio 45103
 888-943-4532
www.keyresin.com

NOT TO
 SCALE

DATE:
 2/24/08

DETAIL:
COVE DETAIL #1

FILE #:
KEY-DTL-11

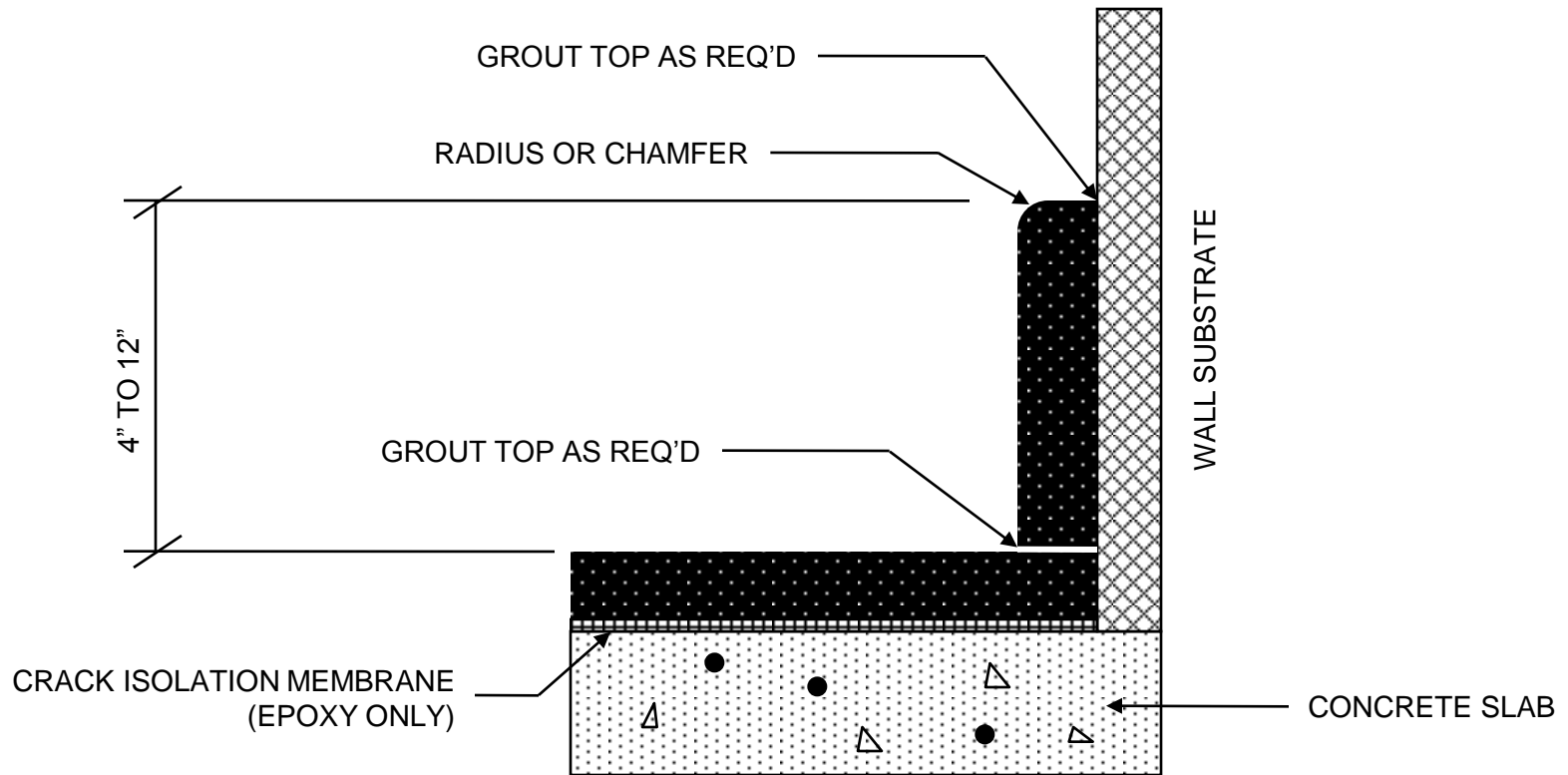

4050 Clough Woods Drive
 Batavia, Ohio 45103
 888-943-4532
www.keyresin.com

NOT TO
 SCALE
 DATE:
 2/24/08

DETAIL: **COVE DETAIL #2**
 FILE #: **KEY-DTL-12**